

# UNIVERSAL/MULTIFLEX

*INTERNATIONAL*

## Factory Parts Catalog

Product No.	MSBH30V7LS1
Series	28' FDBM
Color	stainless
Volts	220V
Wiring Diagram	242132401
Owner's Guide	242130200
Market	Export
Service Data Sheet	242130400
Installation Instructions	242131501

### INTERNATIONAL

P.O. BOX 8020  
CHARLOTTE, NC 28262

Publication No.  
**5995621231**  
12/09/26  
(EN/SERVICE/ECL)  
137

### FRENCH DOOR BOTTOM FREEZER/REFRIGERATOR W/O DISPENSER & ICE MAKER

Model No.  
MSBH30V7L

### FREEZER DRAWER, BASKETS

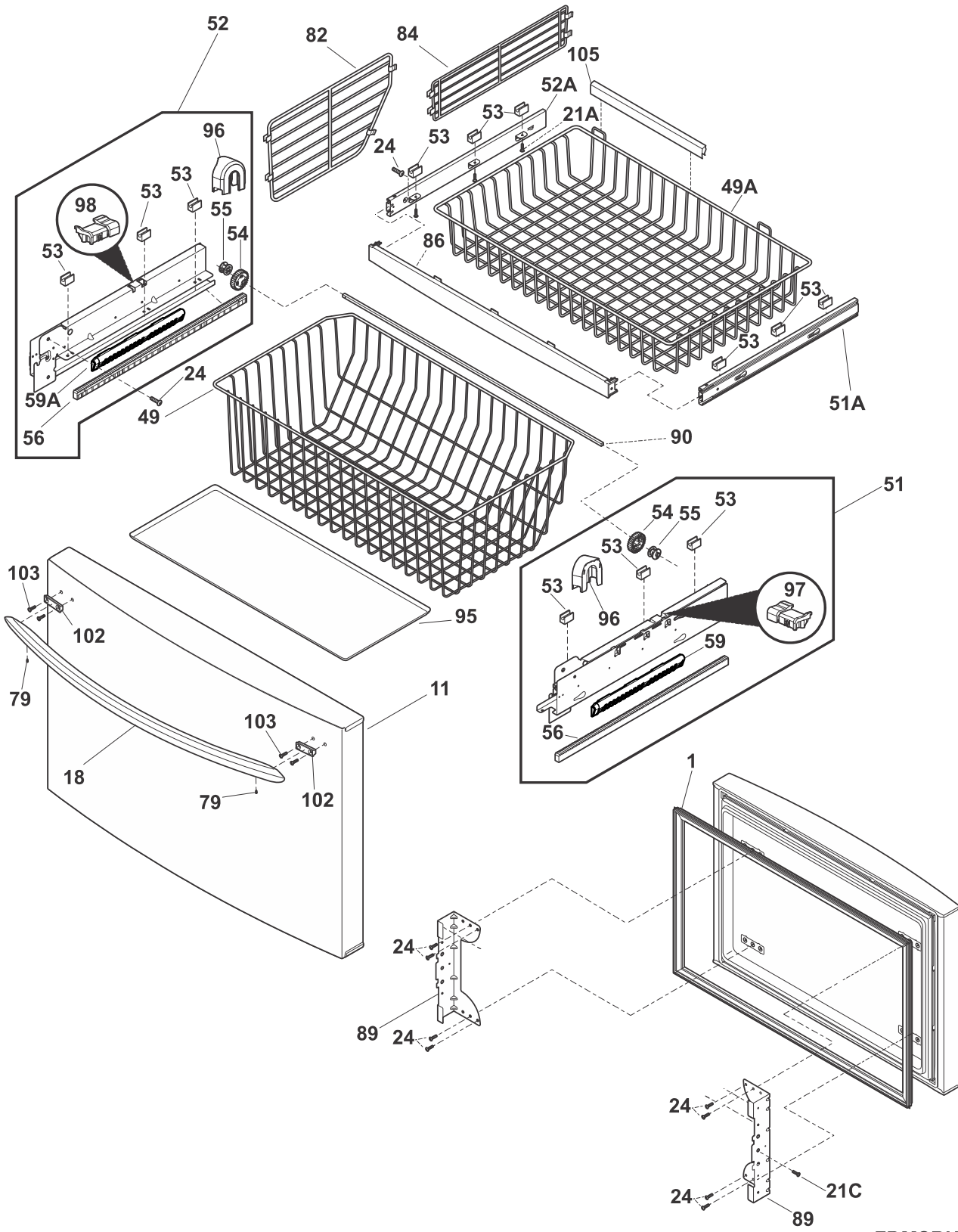

FDMSBH30V7LS1

**FREEZER DRAWER, BASKETS**

POS. NO	PART NO.	DESCRIPTION
1 #	241778308	Gasket-frzr drawer, gray, magnetic
11	241987921	Door-frzr, stainless, complete assy
18	242029401	Handle-door, stainless
18*	241601001	Wrench, allen
18*	241701902	Screwdriver, hex, 3/32", ball driver
21A	241953902	Screw, #8 - 18 X .380, 3
21C	242146401	Screw, ser hex wash hd, 1/4-20 x 5/8, (4)
21C*	242147601	Plate, tapping
24	240383406	Screw, truss hd quad, #10-16 x .500, zinc
49	242026801	Basket-frzr, lower
49A	241780805	Basket-frzr, upper
51	241883604	Slide Assembly, basket lower, RH, freezer drawer
51*	242039701	Screw
51A	241894211	Slide Assembly, basket, RH, freezer drawer
52	241883704	Slide Assembly, basket lower, LH, freezer drawer
52A	241894213	Slide Assembly, basket, LH, freezer drawer
53	241824201	Retainer-basket
54	241770201	Pinion
55	241770301	Pinion-idler
56	242158001	Rack-drawer travel
59	241979702	Closure, drawer
59A	241979701	Closure, drawer
79	218755407	Screw-set, 10-32 x 0.500
82	242026901	Divider, basket
82*	241999901	Guide, divider, plastic (ABS), lower
82*	241999902	Guide, divider, plastic (ABS), lower, LH
84	241780901	Divider, basket, upper
86	241807605	Trim, drawer, stabilizer
89	241972302	Bracket-freezer drawer
89*	241979601	Bumper, rubber
90	241770702	Bar, timing
90*	242011101	Pin-lock
95	241770808	Tray, spill guard
96	242156901	Cover, pinion
97	241926401	Actuator, RH, white, light
98	241926402	Actuator, LH, white, light
102	242029301	Block-handle mtg
103	242077302	Screw, #10 AB flat hd
105	242116801	Trim-basket
*	241899703	Screw, truss head, #10-32 x 1/4, zinc
*	241953901	Screw, #8-18

FRESH FOOD DOOR

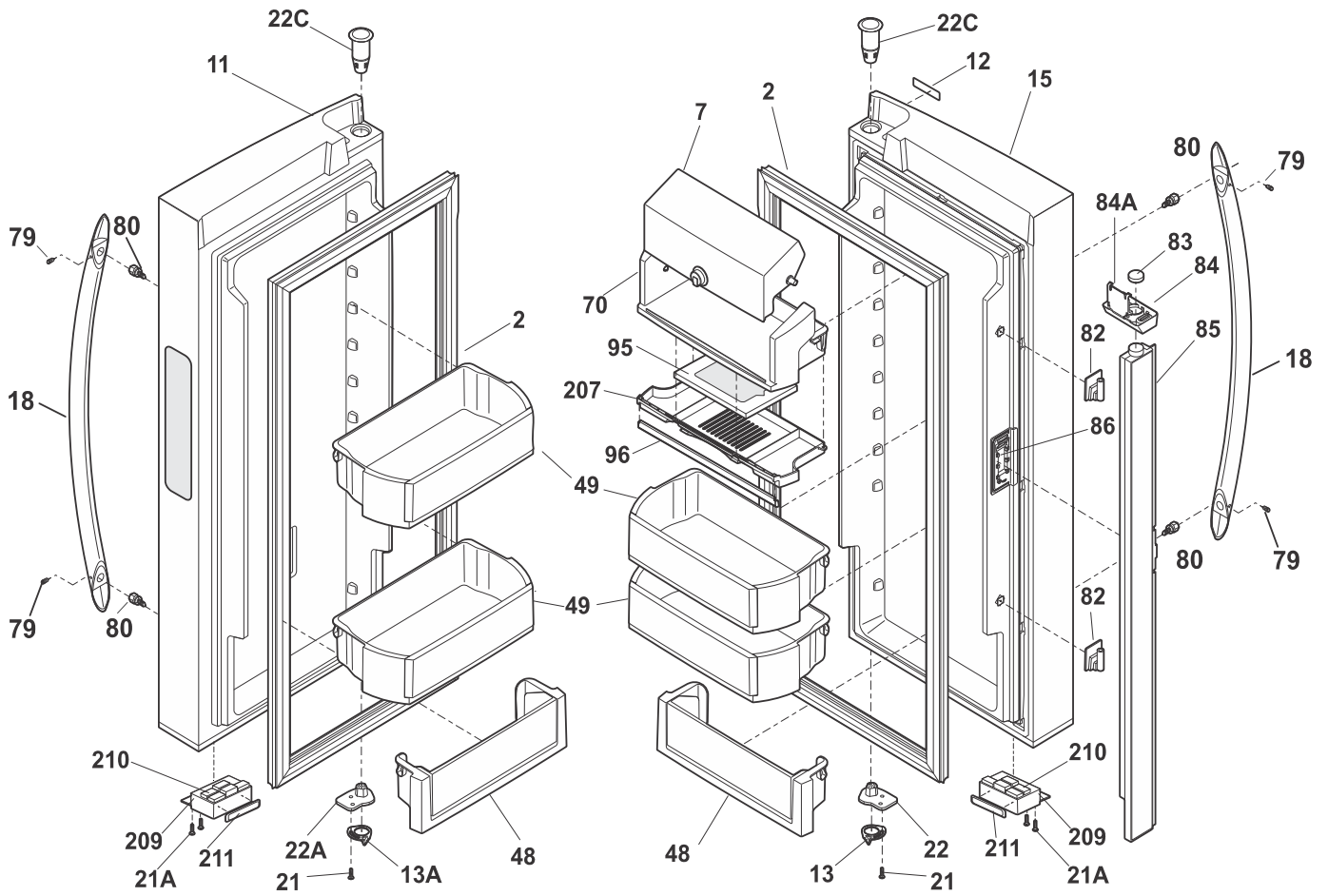

FFMSBH30V7LS1

---

**FRESH FOOD DOOR**

---

POS. NO	PART NO.	DESCRIPTION
2 #	241778307	Gasket-refr door, gray, magnetic
7	242011401	Door-dairy, removable
11	241988082	Door-refr, stainless, LH, non dispenser
12	137095500	Anchor, nameplate
13	241868401	Door Stop, refrig RH, plated
13A	241868402	Door Stop, refr LH, plated
15	241988081	Door-refr, stainless, RH
18	241930101	Handle-door, stainless
18*	241601001	Wrench, allen
18*	241701902	Screwdriver, hex, 3/32", ball driver
21	242017501	Screw, 10-32 x 0.750
21A	241953901	Screw, #8-18
22	242075601	Cam, upper hinge, RH
22A	242075602	Cam, upper hinge, LH
22C	241760401	Bearing, hinge, top
48	242071401	Bin-door, pseudo, white
49	242037201	Bin-door, gallon
70	241804604	Compartment-dairy, removable
79	218755408	Screw-set, 10-32 x 0.375
80	218755504	Screw-shoulder, #10 AB, handle mounting
82	241779401	Hinge-mullion, upper/lower, flipper
83	241812201	Magnet, door
84	242190401	Guide-mullion, magnet cover, flipper
84A	242190501	Cover-mullion, magnet cover
85	241778812	Flipper mullion assembly, w/heater
85*	242064001	Screw
85*#	241788402	Harness-wiring, flipper mullion
86	241779801	Hinge-mullion, center, flipper
95	242047801	Filter-air
96	242048002	Door-air filter
207	242047901	Housing-air filter
209	242021001	Housing-magnet, white
210	241779103	Magnet, door
211	241979601	Bumper, rubber
* #	242045401	Harness-wiring, door
*	242015001	Screw, 8-18 X 1/2
*	242068601	Bumper, RH door

### CABINET

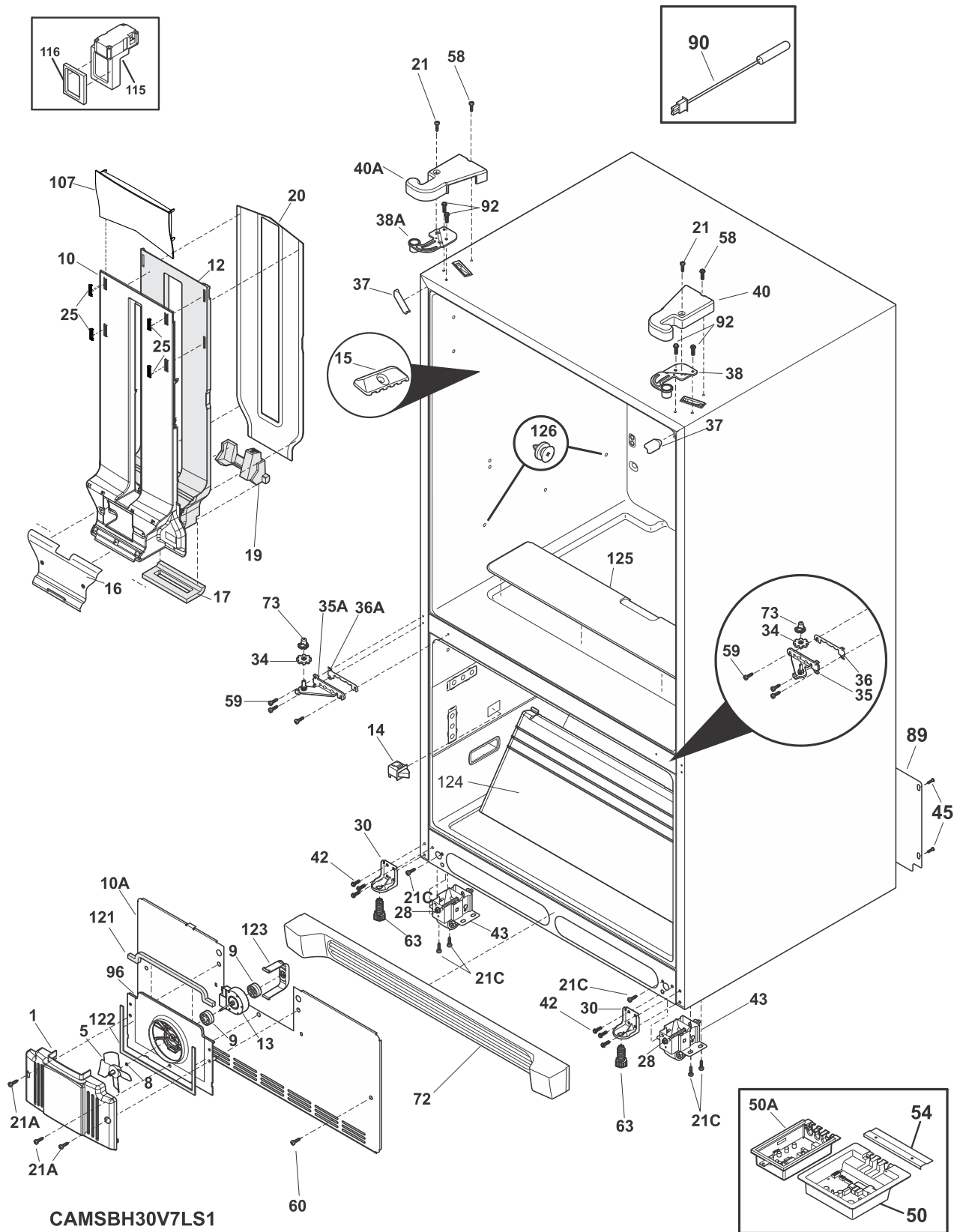

**CABINET**

POS. NO	PART NO.	DESCRIPTION
1	241859701	Cover-fan
5 #	5308000010	Fan Blade, red, evaporator fan
8	215474201	Washer, "slinger", nylon, evap fan shaft
9	241518301	Bushing, motor mounting
10	242072002	Cover-air duct
10*#	242061601	Harness-wiring, air duct
10*	242004802	Foam Strip
10A	241860402	Cover-evap coil, lower
10A*	241860104	Gasket-coil cover
10A*	241860105	Gasket-coil cover
12	242072402	Insulation-air duct
13 #	241509402	Motor, evaporator fan
14 #	240505801	Switch, light/lamp
15 #	241891104	Light-LED
16	242072101	Cover-damper
16*	241953904	Screw, #8-18
16*	242072501	Cover-EPS, damper
17	242071901	Gasket-air duct/liner
19	242072601	Support-EPS damper
20	242072201	Cover-air duct, rear
21	241732101	Screw, 10-32 x 1/2
21A	241953901	Screw, #8-18
21C	218252201	Screw, #8 truss hd, 10-32CA x 0.500
25	241949502	Clip, air vent
28	240335502	Bolt-roller adj, hex washer head, 1/4-20 x 4.020, (2), special
30	241778701	Bracket-anti tip
34	241868301	Washer, hinge, nylon, (2)
35	241763005	Hinge-lower, zinc, RH
35A	241763006	Hinge-lower, zinc, LH
36	241868201	Spacer, door, lower RH
36A	241868202	Spacer, door, lower LH
37	240337614	Trim-cabinet corner, silver mist, (2)
38	241761301	Bracket-upper hinge, RH
38A	241761302	Bracket-upper hinge, LH
40	242099809	Cover-upper hinge, gray, RH
40A	242099810	Cover-upper hinge, gray, LH
42	240578902	Screw, hex head, 1/4-20 x 5/8
43	240335006	Roller Assy, front, (2)
45	241500303	Screw, hex washer head, 8-18AB x 1/2
50 #	241996341	Board-main power, 220
50*#	242068401	Harness-wiring
50A#	241891603	Board-LED power
50A*	241852501	Clip, wiring harness
54	241532401	Channel
58	241853202	Screw
59	240442706	Screw-#10-32 X 3/4, zinc
60	218362501	Screw, hex washer head, 8-18AB x 1.250, spacer, (2)
63	216396900	Screw, leveling foot, plastic, adjustable
72	242054801	Grille/Kickplate
73	242075701	Cam-lower hinge
89	241736406	Cover-access, with label

### CABINET

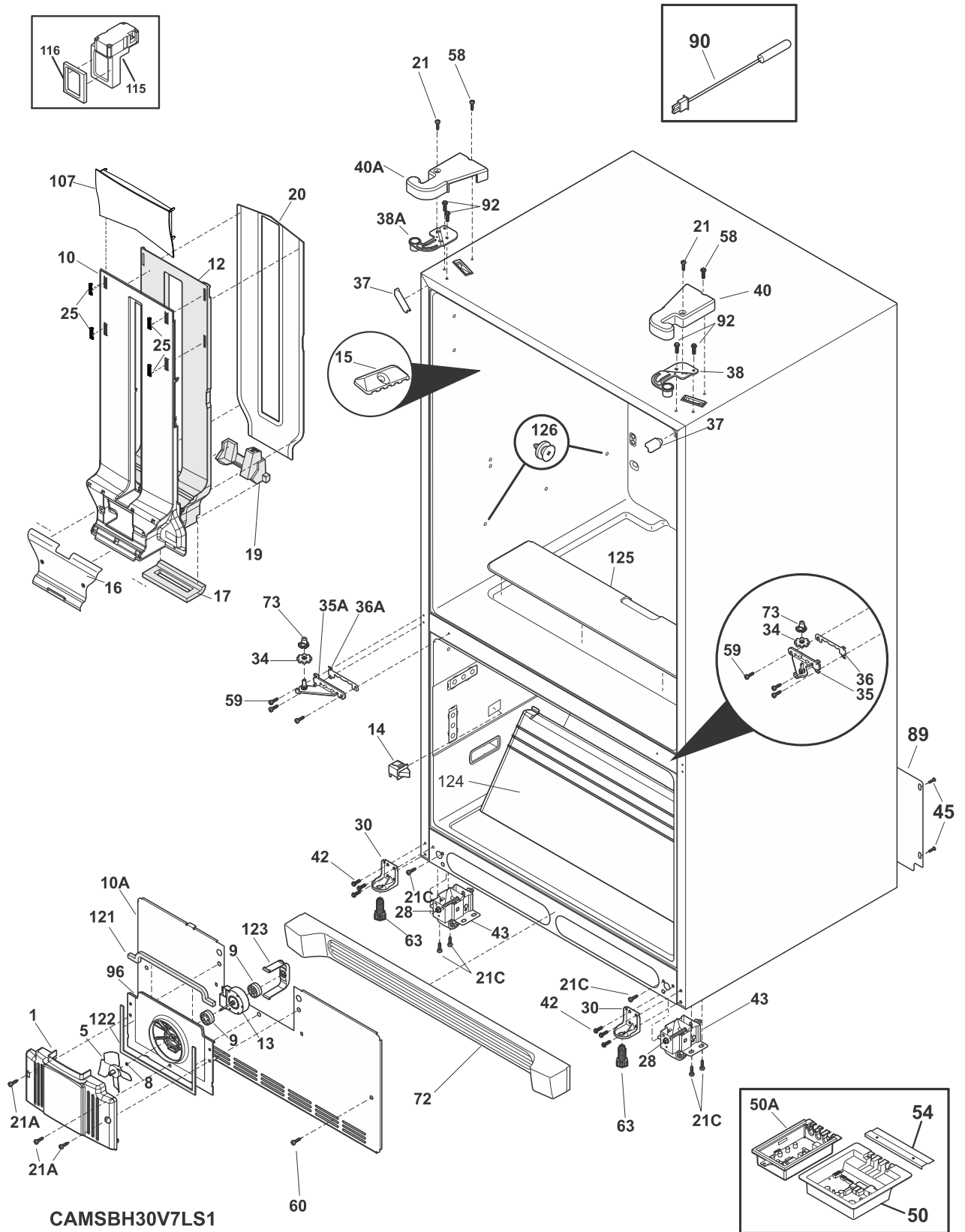



**CABINET**

---

POS. NO	PART NO.	DESCRIPTION
90	240597203	Sensor, (2)
92	241710601	Screw, hex washer hd, 1/4 x 7/8, hinge mtg
96	241860601	Shroud-evap fan mtg
107	241963102	Duct-air, top
115	241518501	Damper, motorized
116	241518601	Seal-damper, foam
121	241860103	Gasket-evap, upper
122	241860102	Gasket-evap, bottom
123	242135301	Clip, evap fan motor, evap fan motor
124	242006902	Duct-air, freezer
125	242071201	Cover, sump
126	242081301	Screw-shoulder
*	240479601	Plug, button, cab liner holes
*	241969001	Cap, screw

SHELVES

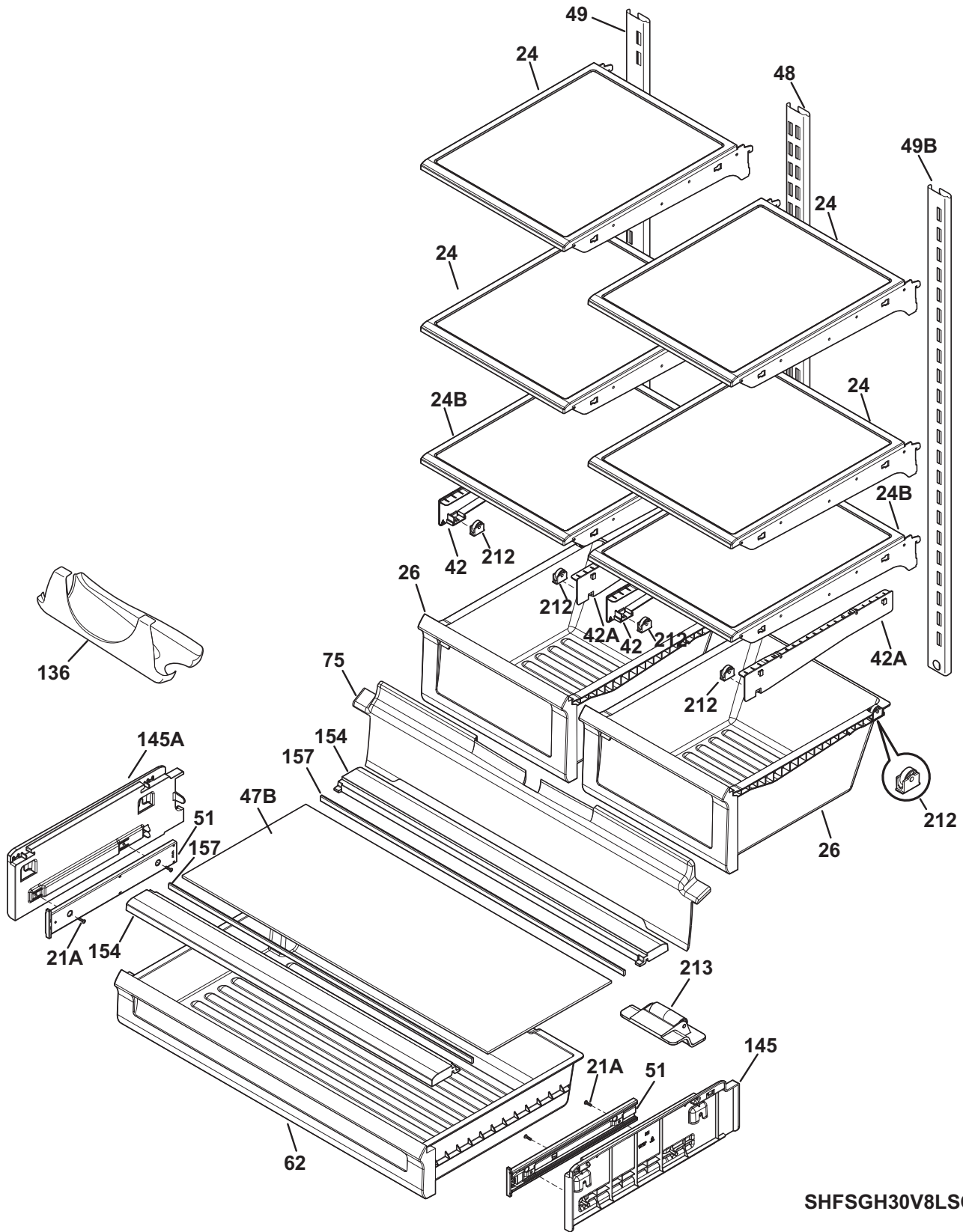

SHFSGH30V8LSO

## SHELVES

---

POS. NO	PART NO.	DESCRIPTION
21A	241953902	Screw, #8 - 18 X .380, 3
24	242068701	Shelf-"Spill-Safe", cantilever, sliding
24B	242068703	Shelf-"Spill-Safe", fixed
26	241801802	Pan-crisper
42	242067901	Support, crspr pan rolle
42*	241953901	Screw, #8-18
42A	242067801	Support, crspr pan rolle
47B	242082301	Glass, deli cover
48	242122101	Channel-shelf mtg, center
49	242122202	Channel-shelf mtg, side, LH
49B	242122301	Channel-shelf mtg, side, RH
51	242065301	Slide-deli
62	242096802	Pan-deli
75	242072702	Shield-light, refr
136	241657701	Dispenser-can, white
145	242082201	Support, rail
145A	242082202	Support, rail
154	242082401	Support
154*	242015001	Screw, 8-18 X 1/2
157	241872201	Beam-crisper cover
212	5304479194	Roller Assembly, crisper pan
213	242010901	Roller Assy, deli pan

**COOLING SYSTEM**

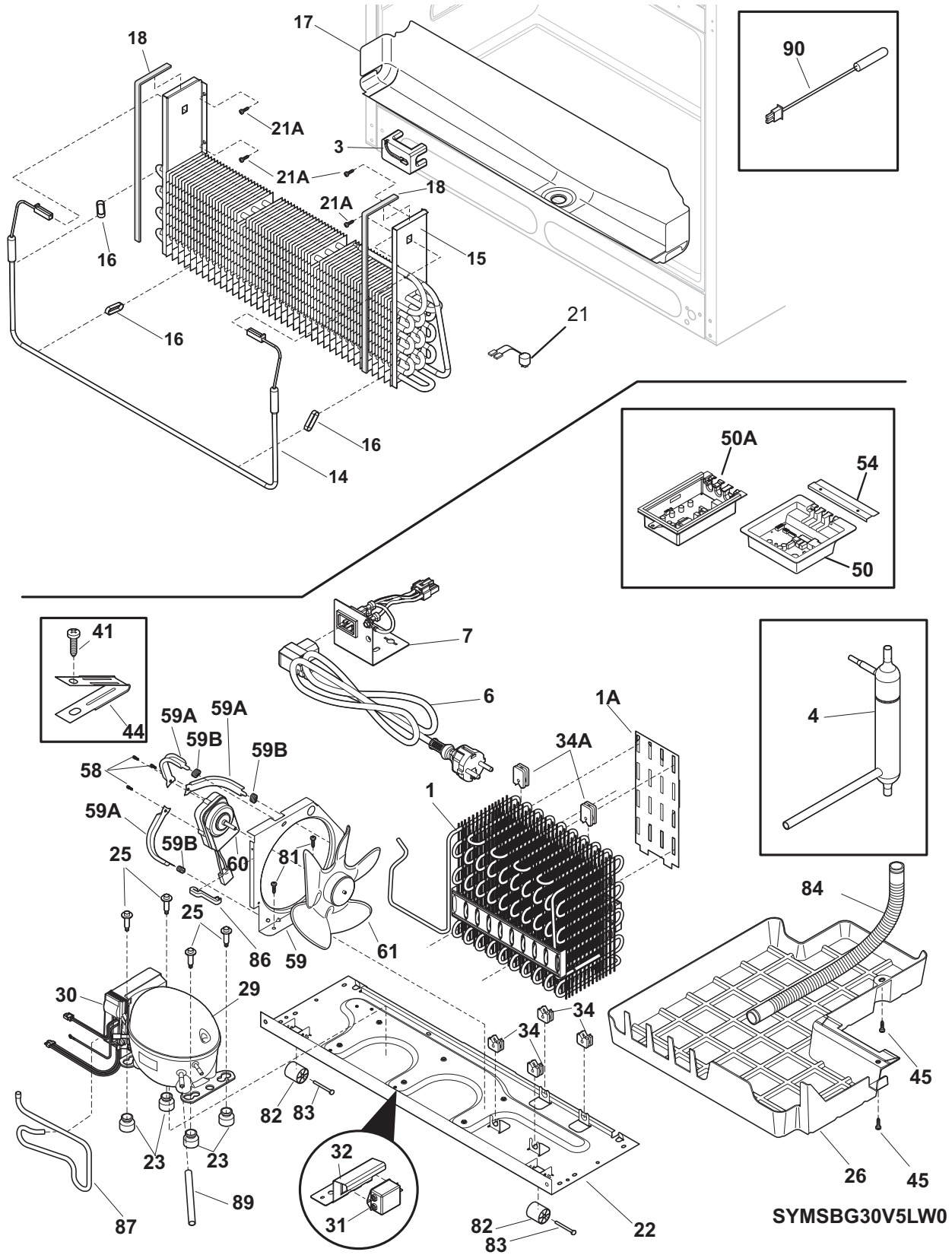

## COOLING SYSTEM

POS. NO	PART NO.	DESCRIPTION
1 #	241862901	Condenser
1A	241987301	Deflector-air, condenser
3	241838401	Block-evap coil, styrofoam insul, RH
4 #	242047603	Drier-filter
6 #	241723307	Cord-service, Britain
6* #	242045301	Harness-wiring, machine compt
7 #	241736102	Bracket, receptacle
14 #	240356227	Heater-defrost, 220 V
15 #	242044501	Evaporator
16	5308000110	Strap-evap/heater, aluminum, (2)
17	241791201	Trough-drain
18	241860101	Gasket, closed cell
21 #	242121701	Thermostat-defrost
21*#	242121702	Thermostat-defrost
21A	218362501	Screw, hex washer head, 8-18AB x 1.250, spacer, (2)
22	241602112	Base-compressor, w/rollers
22*	218252201	Screw, #8 truss hd, 10-32CA x 0.500
23	218513300	Grommet-compr mtg, (4)
25	240491503	Screw-compressor mtg, 1/4-28 x 1.16, (4)
26	241920603	Pan-defrost
29 #	241706206	S/A PUR-COMPRESSOR-EMBRACO, 29 #
30	241577507	Invertor
31 #	241980401	Filter, electrical, EMC
31*#	241980201	Harness-wiring, EMC FILTER, EMC FILTER
32	242052801	Bracket, filter mounting
32*	240433204	Screw, hex washer head, 8-18 x 5/16
34	241929901	Grommet-cond mtg, (4)
34A	241929902	Grommet-cond mtg, (4)
41	240555002	Screw-#8-32 X 3/8
44	215174700	Clamp-service cord, strain relief, galv steel
45	5304455650	Screw, hex washer head, 8-15A x 0.625, Low Profile
50 #	241996341	Board-main power, 220
50*#	242068401	Harness-wiring
50A#	241891603	Board-LED power
50A*	241852501	Clip, wiring harness
54	241532401	Channel
58	240569202	Screw, 8-18 X .500
59	240315506	Shroud-cond fan, cond fan motor
59*	240346701	Tape-foam seal, shroud
59A	240346502	Bracket-support, cond mtr, (3)
59B	240346601	Grommet-bracket, (3)
60 #	241657102	Motor-condenser fan
61	241639501	Blade-condenser fan
81	240359403	Screw-fan shroud, (2)
82	5304418225	Roller, compressor base, rear, (2)
83	5304455655	Rivet, flat head, 1/4 OD x 1-3/4, roller pin
84	241830902	Tube-drain, lower
84*	242036801	Clip-tube, drain
86	240409302	Spacer-cond tube, black
87	241846302	Tube-suction, jumper
89	215346900	Tube-process
90	240597203	Sensor, (2)
90*	241842301	Cap-thermistor
* #	5303918445	Heat Exchanger Kit, suction line, service
* #	241510904	Harness-dispenser, grounding
*	5303918428	Hot Tube Repair Kit, service
*	3205266	Edge Protector, wiring harness
*	218515401	Clip-grille
*	241947701	Spacer, heat exchanger

**CONTROLS**

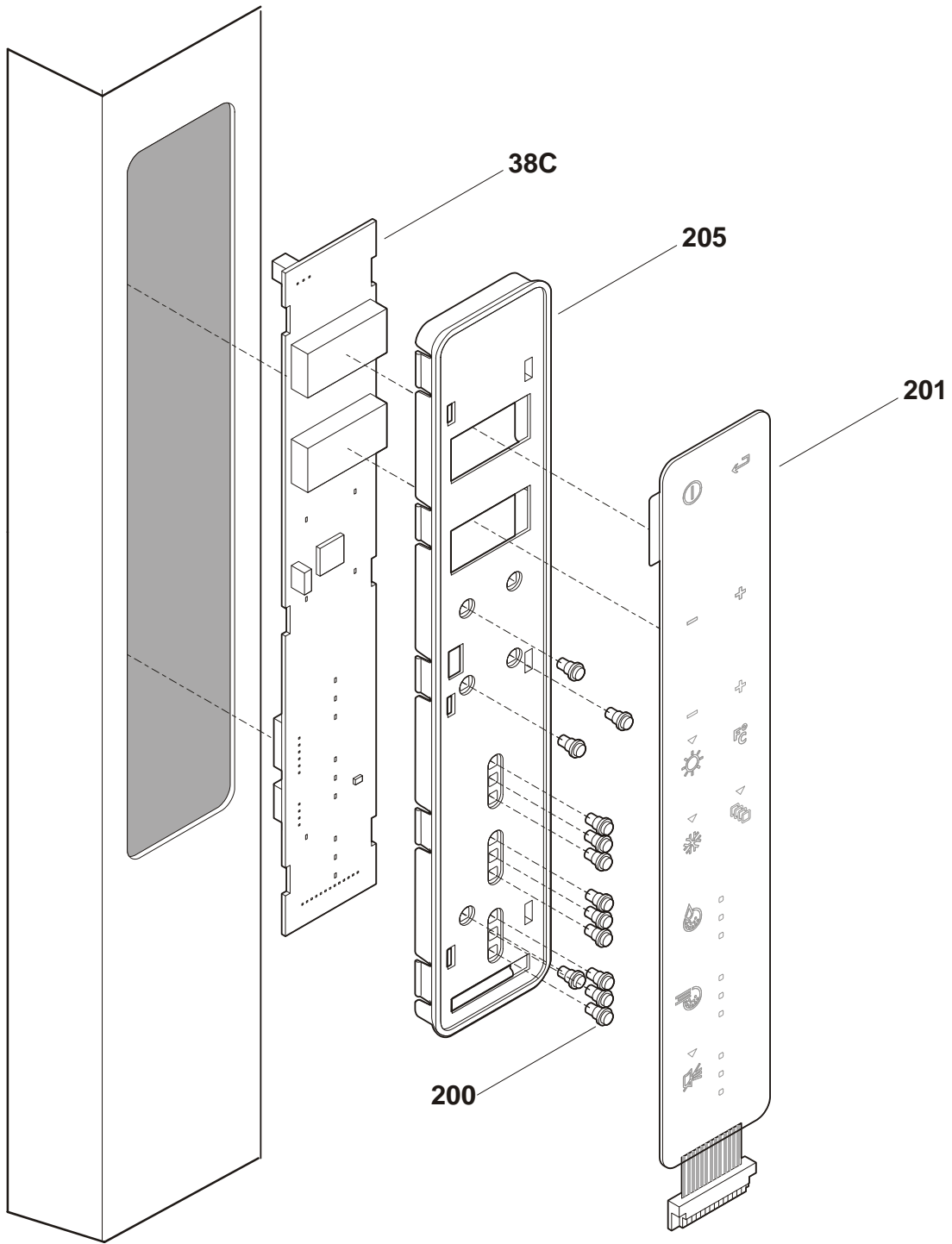

FD58XNDAAA0

**CONTROLS**

---

POS. NO	PART NO.	DESCRIPTION
38C#	242048305	Board-control, 38C#
200	241609201	Light Pipe
201	242129602	Switch-membrane
205	242066202	Housing, disp/controls
*	241510904	Harness-dispenser, grounding

WIRING DIAGRAM

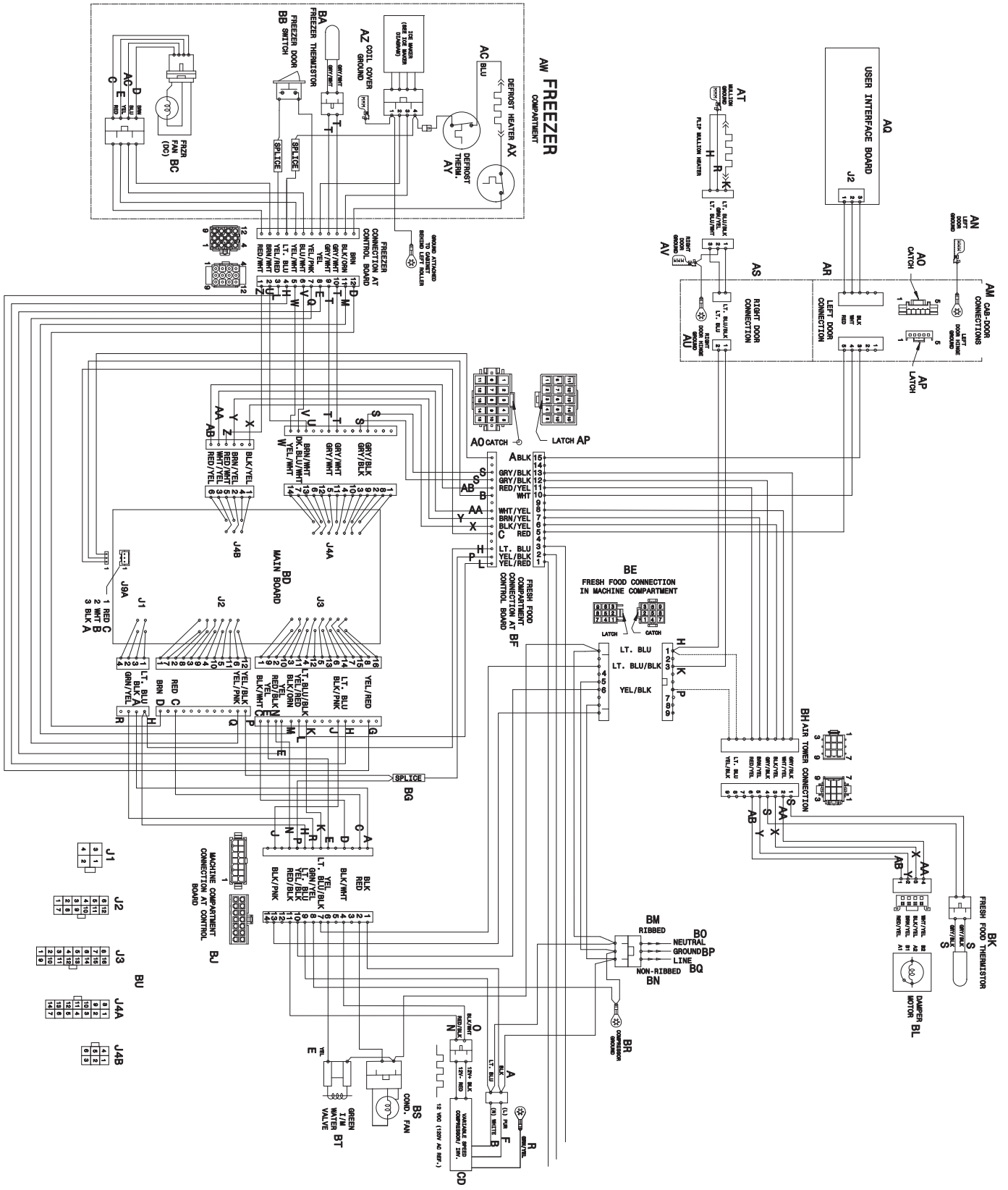



WIRING DIAGRAM

